

光電/半導體/電子業/食品/藥廠/生技/醫療業

#### A、應用

- ※ 風扇過濾裝置(FFU) 是一種提供淨化空氣給無塵室的設備，適用於光電，半導體，液晶等產業，其安裝於天花板的空間。
- 較大型的無塵室，可同時佈滿數百台，甚至數仟台，或數萬台的風扇過濾裝置。
- ※ 我們研發設計的理念是節省能源，降低運轉費用，及以整體無塵室專用的設計，諸如低噪音，高效率等，來降低成本，期能滿足您對無塵室施工、運轉、維修，保養等多方面之需求，依實際需要，亦可訂製超薄迷你型風扇過濾裝置(FFU)

#### A、Applications

- ※ Fan Filter Unit (FFU) is air cleaning equipment to supply purified air to the clean room for manufacturing photo-electronics, semi-conductor, liquid crystal, etc.  
The installation space is the system ceiling grid.  
For a large clean room, the number of FFU is from several hundreds to thousands.
- ※ We developed DEVISER FFU units basing upon the concepts including, to reduce running cost by saving energy, and to reduce initial cost by total design of clean room; such as noise specifications, to meet all the requirements for constructing, operating, and maintaining clean rooms. Custom thin & Mini type of FFU by demand is available.

#### B、特點

- ※ 經由電腦分析計算設計的鋁合金製，三段或無段變速渦輪風扇，效率高，噪音低
- ※ 搬運把手使安裝及搬運更容易
- ※ 快速安全接頭電源連結方式，最適合小型無塵室使用
- ※ 可選配0.12 $\mu$ m 99.9999% ULPA 過濾器，使用於嚴格清淨度要求的無塵區域

#### B、Features

- ※ 3 section or variable speed airfoil turbo fan made by aluminum alloy, which pursued the most suitable designed by computer analysis, provides high efficiency and low-noise.
- ※ A carrying handle makes transportation and installation easier.
- ※ A safety socket block for connecting electric power is suitable for a small clean room.
- ※ An optional ULPA filter, which is 99.9999% efficiency at 0.12 microns, is available to meet the extremely critical clean area needs.

#### C、FFU應用於無塵室的優點

- ※ 清淨度Class1~100,000 皆可設定，且可分區各別設定
- ※ 天花板後方為負壓，可減低洩漏的可能性
- ※ 變換FFU 的安裝，可以作成隔間或穿牆方式的無塵室
- ※ 吹出風量，亦可分區個別設定
- ※ 改變FFU 的配置方式，可彈性擴建或改造無塵室

#### C、Advantages of clean room with FFU method

- ※ The degree of cleanliness from class 1 up to 100,000 can be set at individual area.
- ※ The back in the ceiling is a low-pressure area, the potential of leakage is extremely low.
- ※ Through the wall method is possible by the arrangement of layout of FFU.
- ※ The volume of the air flow can be set at each area.
- ※ Flexible increase or change of the clean room is possible by the arrangement of FFU.

## FFU—S (AC type)

依據AMCA 210-85 Figure 12 風機測試規範所得之結果

特性：

- A、三段或無段變速渦輪風扇，低噪音全密閉型不發塵，特殊導流、風道設計，降低壓損與噪音的產生，提高風機靜壓。
- B、維修保養簡便，控制面板附有ON、OFF 開關、電源指示燈、運轉指示燈、故障異常指示燈、故障輸出a、b 接點。
- C、風車漿輪採後傾式，振動平衡：G2.5 級

The test results are obtained by being based on FFU test specification of AMCA 210-85 Figure 12.

Features：

- A、3 speed sections selection or variable speed turbo fan, low noise, completely closed, no dust being generated, design of the air diversion & air duct decrease the pressure drop & noise level and improve fan static pressure.
- B、easy maintenance & repair, the control panel is with ON/ OFF switch, indicator lamp, running indicator lamp, failure abnormal indicator lamp, and failure output of a & b.
- C、with backward inclined fan impeller, dynamic vibration balance: G2.5



▲ FFU-S420S



▲ FFU-S430S



▲ FFU-S525



▲ FFU-S440S

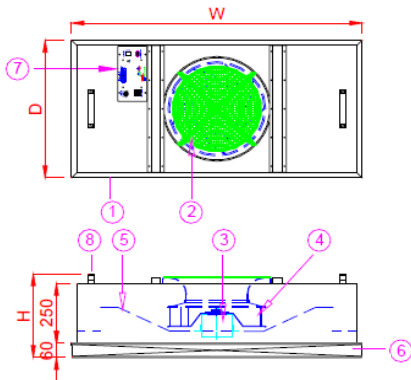

①	本體 Body Assembly
②	進風口 Air Inlet Net
③	馬達 Fan Motor
④	風扇 Fan
⑤	導流板 Difusser
⑥	高效濾網 HEPA Filter
⑦	控制面板 Control panel
⑧	把手 Handle

項目 Item		FFU-S420S	FFU-S430S	FFU-S525	FFU-S440S								
外部尺寸 Outside Dimension	W	1175	1175	1475	1175								
	D	575	875	725	1175								
	H	360	360	360	360								
本體材質 Body Construction		SUS430 & 鍍鋅板 AL-Zn											
HEPA ULPA	特性 Features	鋁框，捕集效率 99.99% , 0.3um / 99.999% , 0.1~0.12um Aluminum Frame , Filtration Efficiency 99.99% , 0.3um / 99.999% , 0.1~0.12um											
	尺寸 Dimension	1170×570×50	1170×870×50	1470×720×50	1170×1170×50								
馬達 Fan motor		AC 感應馬達 induction motor											
電源供應 Power Supply		AC 1Ø 220V 60Hz											
風速段數 Air Speed		Lo	Mi	Hi	Lo	Mi	Hi	Lo	Mi	Hi	Lo	Mi	Hi
機外靜壓 External Static Pressure (Pa)		160	160	160	160	160	160	160	160	160	160	160	160
風速 Air Velocity (m/s)		0.36	0.45	0.5	0.4	0.45	0.5	0.4	0.45	0.5	0.4	0.45	0.5
風量 Air Volume (CMM)		15	18	20	24	28	30	24	28	30	30	35	40
噪音 Noise (db)		53	56	59	50	55	58	50	55	58	55	58	60
消耗電力 Power consumption(W)		110	130	149	198	211	225	198	211	225	210	230	250
電流 Current (A)		0.47	0.55	0.68	0.78	0.85	0.92	0.78	0.85	0.92	0.95	1.05	1.14
重量 Total Weight (Kg)		37		43		46		57					

特殊尺寸規格可依客戶需求製作 Customized size and specification are available to meet customer's requirement.

**FFU—SD (DC type)**

※ 電機採用DC 無刷變頻馬達·節能·低噪音

※ 電源供應：AC 單相220V 50/60HZ

※ FFU motor is with DC brushless frequency converter motor. So that, it is with superior features of energy save and low noise level as well.

※ Power supply : AC220V, single phase, 50/60HZ.



▲ FFU-SD420S



▲ FFU-SD430S



▲ FFU-SD525



▲ FFU-SD440S

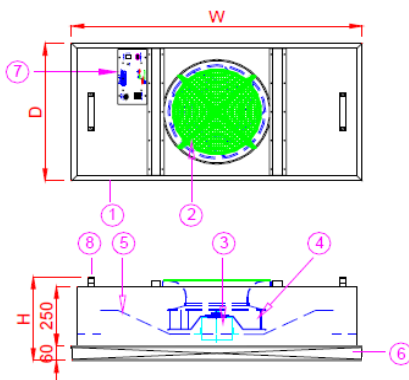

①	本體 Body Assembly
②	進風口 Air Inlet Net
③	馬達 Fan Motor
④	風扇 Fan
⑤	導流板 Difuser
⑥	高效濾網 HEPA Filter
⑦	控制面板 Control panel
⑧	把手 Handle

項目 Item		FFU-SD420S	FFU-SD430S	FFU-SD525	FFU-SD440S								
外部尺寸 Outside Dimension	W	1175	1175	1475	1175								
	D	575	875	725	1175								
	H	360	360	360	360								
本體材質 Body Construction		SUS430 & 鍍鋅鋅板 AL-Zn											
HEPA ULPA	特性 Features	鋁框, 捕集效率 99.99%, 0.3um / 99.999%, 0.1~0.12um Aluminum Frame, Filtration Efficiency 99.99%, 0.3um / 99.999%, 0.1~0.12um											
	尺寸 Dimension	1170×570×50	1170×870×50	1470×720×50	1170×1170×50								
馬達 Fan motor		DC 無刷變頻馬達 DC brushless frequency converter motor											
電源供應 Power Supply		AC 1Ø 220V 60Hz											
風速段數 Air Speed		Lo	Mi	Hi	Lo	Mi	Hi	Lo	Mi	Hi	Lo	Mi	Hi
機外靜壓 External Static Pressure(Pa)		160	160	160	160	160	160	160	160	160	160	160	160
風速 Air Velocity (m/s)		0.36	0.45	0.5	0.4	0.45	0.5	0.4	0.45	0.5	0.4	0.45	0.5
風量 Air Volume (CMM)		15	18	20	24	28	30	24	28	30	30	35	40
噪音 Noise (db)		52	57	59	50	55	58	50	55	58	55	58	60
消耗電力 Power consumption(W)		62	80	95	100	102	123	100	102	123	150	158	200
電流 Current (A)		0.34	0.44	0.5	0.39	0.46	0.56	0.39	0.46	0.56	0.58	0.69	0.9
重量 Total Weight (Kg)		37			43			46			57		

特殊尺寸規格可依客戶需求製作 Customized size and specification are available to meet customer's requirement.

## MS—S (AC type)

超薄型FFU 應用於微環境的優點及特殊環境空間

- ※ 清淨度Class1~10,000 皆可設定，且可分區各別設定
- ※ 變換FFU 的安裝，可以作成隔間或穿牆方式的無塵室
- ※ 吹出風量，亦可分區個別設定
- ※ 改變FFU 的配置方式，可彈性擴建或改造無塵室
- ※ 適用於高等級微環境的優點及特殊空間環境

The specific features of super thin type FFU used for minor environmental situations and specific spaces

- ※ The degree of cleanliness from class 1 up to 100,000 can be set at individual area.
- ※ Through the wall method is possible by the arrangement of layout of FFU.
- ※ The volume of the air flow can be set at each area.
- ※ Flexible increase or change of the clean room is possible by the arrangement of FFU.
- ※ It can be used for critical cleanliness level minor environmental situations and specific spaces.



▲ MS-S220S



▲ MS-S420S



▲ MS-S430S



▲ MS-S440S

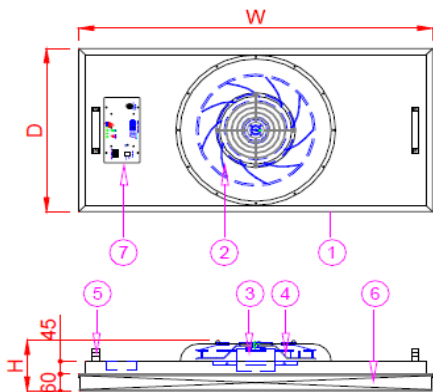

①	本體 Body Assembly
②	進風口 Air Inlet Net
③	馬達 Fan Motor
④	風扇 Fan
⑤	把手 Handle
⑥	高效濾網 HEPA Filter
⑦	控制面板 Control panel

項目 Item		MS-S220S	MS-S320S	MS-S420S	MS-S430S	MS-S440S
外部尺寸 Outside Dimension	W	575	920	1175	1175	1175
	D	575	575	575	875	1175
	H	180	180	180	180	180
本體材質 Body Construction		SUS430 & 鍍鋁鋅板 AL-Zn				
HEPA ULPA	特性 Features	鋁框，捕集效率 99.99%，0.3um / 99.999%，0.1~0.12um Aluminum Frame，Filtration Efficiency 99.99%，0.3um / 99.999%，0.1~0.12um				
	尺寸 Dimension	570×570×50	915×570×50	1170×570×50	1170×870×50	1170×1170×50
馬達 Fan motor		AC 感應馬達 induction motor				
電源供應 Power Supply		AC 1Ø 220V 60Hz				
風速 Air Velocity (m/s)		0.5				
風量 Air Volume (CMM)		9	15	20	30	40
消耗電力 Power consumption(W)		96	164	165	300	330
重量 Total Weight (Kg)		11	17	21	40	47.5

特殊尺寸規格可依客戶需求製作 Customized size and specification are available to meet customer's requirement.

## MS—SD (DC type)

※ 電機採用DC 無刷變頻馬達 · 節能 · 低噪音

※ 電源供應：AC 單相220V 50/60HZ

※ FFU motor is with DC brushless frequency converter motor. So that, it is with superior features of energy save and low noise level as well.

※ Power supply：AC220V, single phase, 50/60HZ.



▲ MS-SD220S



▲ MS-SD420S



▲ MS-SD430S



▲ MS-SD440S

項目 Item		MS-SD220S	MS-SD320S	MS-SD420S	MS-SD430S	MS-SD440S
外部尺寸 Outside Dimension	W	575	920	1175	1175	1175
	D	575	575	575	875	1175
	H	180	180	180	180	180
本體材質 Body Construction		SUS430 & 鍍鋁鋅板 AL-Zn				
HEPA ULPA	特性 Features	鋁框, 捕集效率 99.99%, 0.3um / 99.999%, 0.1~0.12um Aluminum Frame, Filtration Efficiency 99.99%, 0.3um / 99.999%, 0.1~0.12um				
	尺寸 Dimension	570×570×50	915×570×50	1170×570×50	1170×870×50	1170×1170×50
馬達 Fan motor		DC 無刷變頻馬達 DC brushless frequency converter motor				
電源供應 Power Supply		AC 1Ø 220V 60Hz				
風速 Air Velocity (m/s)		0.5				
風量 Air Volume (CMM)		9	15	20	30	40
消耗電力 Power consumption(W)		60	90	117	180	230
重量 Total Weight (Kg)		11	17	21	40	47.5

## MAC

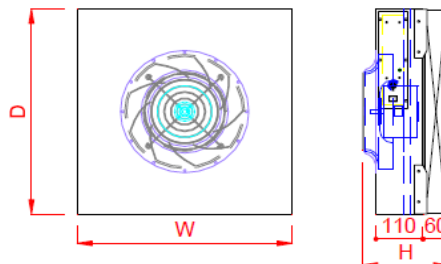

項目 Item		AC type			DC type		
		MAC-S3	MAC-S5	MAC-S7	MAC-SD3	MAC-SD5	MAC-SD7
外部尺寸 Outside Dimension	W	303	403	503	303	403	503
	D	303	403	503	303	403	503
	H	200	200	200	200	200	200
本體材質 Body Construction		SUS430 & 鍍鋁鋅板 AL-Zn					
HEPA ULPA	特性 Features	鋁框, 捕集效率 99.99%, 0.3um / 99.999%, 0.1~0.12um Aluminum Frame, Filtration Efficiency 99.99%, 0.3um / 99.999%, 0.1~0.12um					
	尺寸 Dimension	300×300	300×300	300×300	300×300	300×300	300×300
馬達 Fan motor		AC 感應馬達 induction motor			DC 無刷變頻馬達 DC brushless frequency converter motor		
電源供應 Power Supply		AC 1Ø 220V 60Hz					
風速 Air Velocity (m/s)		0.5					
風量 Air Volume (CMM)		3	5	7	3	5	7
消耗電力 Power consumption(W)		38	45	45	26	28	38
重量 Total Weight (Kg)		7	10	12	7	10	12

特殊尺寸規格可依客戶需求製作 Customized size and specification are available to meet customer's requirement.